



WL系列立式排污泵

WL SERIES VERTICAL SEWAGE PUMP



上海连成（集团）有限公司
SHANGHAI LIANCHENG (GROUP)CO.,LTD.

地址：上海市江桥镇曹安公路3616-3618号
邮编：201812
总机：(021) 59138888
传真：(021) 59136782
800免费咨询电话：800-820-5009
400免费咨询电话：400-188-3339

Address:3616-3618 Can'an Road, Jiangqiao Shanghai
P.C.: 201812
Switchboard: (021) 5913888
Fax: (021) 59136782
800 Free consultation Tel: 800-820-5009
400 Free consultation Tel: 400-188-3339



连成集团微信订阅号

目 录

CONTENTS

产品简介 Brief account of product	1
产品特点 Characteristic	1
产品主要用途 Main purpose	2
型号说明 Model description	2
泵的使用条件 Conditions of use	2
结构说明 Description of structure	3
WL系列泵性能参数表 WL Series pump performance table	4
WL 型立式排污泵安装尺寸图及安装尺寸表 WL Type vertical sewage pump installation dimension figure and dimension table	7
泵的安装和使用 Installation and use	15
泵的维护和保养 Maintenance	15
故障原因及排除方法 Failures causes and troubleshooting	16
管路损耗参考表 Reference table for pipeline loss	17

产品简介 Brief account of product

WL系列立式排污泵是本公司在引进国内外先进技术,根据用户的要求及使用条件,进行合理的设计而研制开发成功的新一代产品。具有高效节能、功率曲线平坦、无堵塞、防缠绕、性能好等特点。

该系列泵叶轮采用单(双)大流道叶轮,或双叶片、三叶片叶轮,独特的叶轮结构,使其具有非常好的过流性,配以合理的蜗室,使泵具有高效率,并能顺利地输送含大颗粒固体、食品塑料袋等长纤维或其它悬浮物的液体。能抽送的最大固体颗粒直径80~250mm,纤维长度300~1500mm。

WL系列泵水力性能好,功率曲线平坦,经测试各项性能指标达到有关标准规定,产品投放市场后以其独特的功效,可靠的性能和质量而受到广大用户的欢迎和好评。

产品特点 Characteristic

1、独特的叶轮设计,采用大流道抗堵塞水力部件,大大提高了污物的通过能力,能有效地通过纤维物质和固体颗粒。

2、泵与电机同轴直接传动,属机电一体化产品,结构紧凑,性能稳定。

3、适用性强,适用于输送城市生活污水、工矿企业污水等。

4、操作方便,维护保养费用低;整机可置于室外工作,无需机房,可节省大量基建费用。

5、机械密封的材质为硬性耐磨耐腐蚀碳化钨,具有耐用、耐磨等特点,可以连续安全运行8000小时以上。

6、电机配套合理,整机效率高,水力性能好,运转噪音低。

WL series vertical sewage pump is a new-generation product successfully developed by this Co. by way of introducing the advanced know-how from both at home and abroad, upon the requirements and conditions of use of the users and reasonable designing and features high efficiency, energy saving, flat power curve, non-block-up, wrapping-resisting, good performance etc.

This series pump uses single(dual) great flow-path impeller or the impeller with dual or three blades and, with the unique impeller's structure, has a very good flow-passing performance, and equipped with reasonable spiral housing, is made to be high effective and able to transport the liquids containing solids, food plastic bags etc. long fibres or other suspensions, with the maximum diameter of the solid grains 80~250mm and the fibre length 300~1500mm.

WL series pump has a good hydraulic performance and a flat power curve and, by testing, each of its performance index reaches the related standard. The product is greatly favoured and evaluated by the users since its being put into the market for its unique efficiency and reliable performance and quality.

1. The unique impeller design and the great flow-path block-up resisting hydraulic parts greatly enhance the ability for sewage to pass and effectively have fibre matters and solid grains passing through.

2. It belongs to the integrated electromechanical product with both pump and motor in one shaft to directly drive, resulting in compact structure and stable performance.

3. Of a strong suitability, suitable for transporting city's living sewage, factory, mine etc. enterprises' sewage.

4. Easy operation, low cost for maintenance; can be overallly placed outdoors to work without need of machine room, saving great deal of construction fees.

5. Mechanical seal is made of hard wearable corrosion-proof tungsten carbide and features durability and wearability and can safely and continually run over 800h.

6. The motor is reasonably fitted with, high overall efficiency, good hydraulic performance and low noise at running.

产品主要用途 Main purpose

该产品主要适用于输送城市生活污水、工矿企业污水、泥浆、粪便、灰渣及纸浆等浆料,还适用于循环水泵、给排水用泵;勘探、矿山配套附机、农村沼气池、农田灌溉等其它用途

This product is mainly used to transport city's living sewage, factory, mine etc. enterprises' sewage, slurry, night soil, ash and dregs, paper pulp etc. also for cycle water pump, water supply and drain pumps, exploration, mine fitted auxiliary machine, methane-generating pit in countryside, farming irrigation etc. purposes.

型号说明 Model description

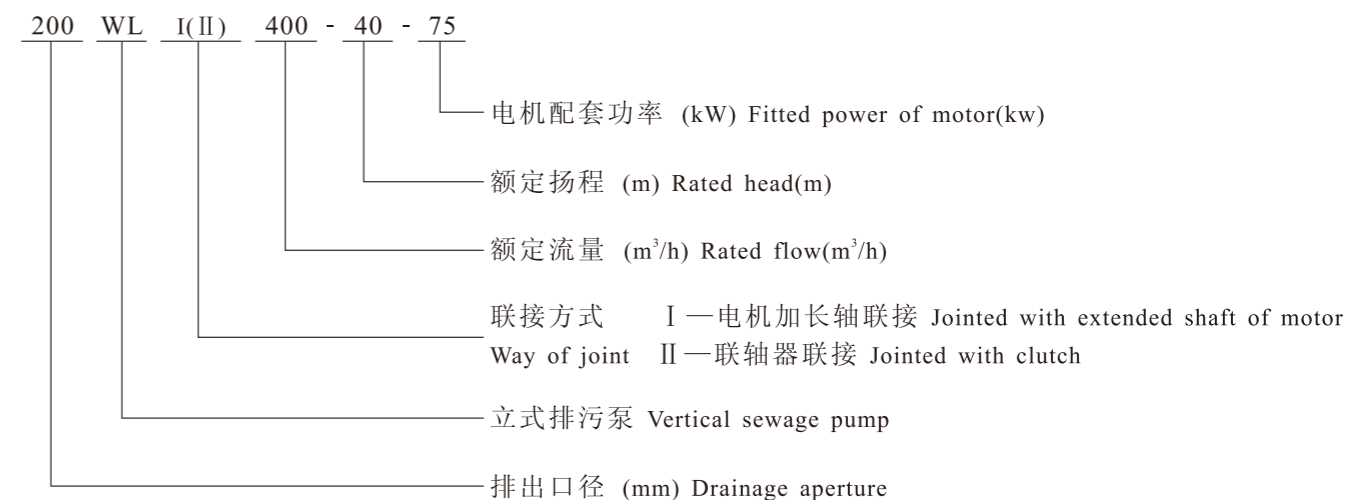

泵的使用条件 Conditions of use

- 1、介质温度不超过80℃,介质密度为1200kg/m³。
- 2、铸铁材质的介质PH值在5~9范围内。
- 3、泵、机为整体结构,其工作环境温度不得超过40℃,相对湿度不超过95%。
- 4、一般情况下,泵必须在规定扬程范围内工作,保证电机不超载,如需在低扬程状态下工作,应在订货时说明,以便厂家合理选型。

1. Medium temperature not over 80℃, medium density 1200kg/m³.
2. The PH value of the medium in cast-iron material within 5-9.
3. Both pump and motor are integrally structured, the ambient temperature in the place where it works is not allowed over 40℃, the RH not over 95%.
4. The pump must work within the set head range in general so as to ensure the motor not to be overloaded. Make a note at order if it works in a low head state so as for this company to take a reasonable model selection.

结构说明 Description of structure

WL系列立式无堵塞排污泵为单吸蜗壳式泵，泵内装有无堵塞防缠绕型单(双)大流道叶轮。

该系列排污泵具有两种结构型式，一种是电机采用加长轴与泵叶轮直接联接，电机与泵为同轴一体结构；另一种是电机装在与泵体连为一体的支架上，电机轴与泵轴之间用联轴器联接，电机采用标准立式电机。

从电机上方看，泵为顺时针方向旋转。

每种结构型式具有两种不同的进水方式，与两种不同结构的底座连接。一是进口为水平吸入，具有转角功能，可根据具体使用条件，调整进、出口的夹角，以便于管路联接；二是进口为垂直轴向式吸入，以便于立式安装。

WL series vertical non-block-up sewage pump is a single-suction spiral casing type one and inside of it there are non-block-up wrapping-resisting single(dual) great flowpath impeller(s) mounted.

Two structural forms with the pump, one is the coaxial structure of both pump and motor, in which the extended shaft of the motor is directly connected to the impeller of the pump; the other is the motor is mounted on the stand integrated with the pump casing and a clutch is used to have both shafts of the motor and the pump connected, the motor used is the standard vertical one.

The pump moves CW viewing from the top of the motor.

Two water inlet modes with each form of structure, they are connected to the two foundations of different structures: one is horizontal suck-in on the inlet and has an angle-turnable function to adjust the angle between both inlet and outlet upon the conditions of use so as to help for pipeline joint; the other is vertical axial suck-in on the inlet for the sake of vertical installation.

WL系列泵性能参数表 WL series pump performance table

序号 No.	型号 Model	流量 Capacity		扬程 Head (m)	转速 Speed (r/min)	功率 Power (kW)	效率 Eff. (%)	汽蚀余量 (NPSH)r (m)	重量 Weight (kg)	排出口径/吸入口径 Outlet caliber/Inlet caliber (mm)
		(m ³ /h)	(L/s)							
1	50WL 15-8-0.75	15	4.2	8	2825	0.75	52	1.1	30	50/50
2	50WL 15-12-1.1	15	4.2	12	2825	1.1	52	1.1	32	50/50
3	50WL 15-16-1.5	15	4.2	16	2840	1.5	52	1.1	40	50/50
4	50WL 15-22-2.2	15	4.2	22	2840	2.2	52	1.4	45	50/50
5	50WL 15-30-3	15	4.2	30	2880	3	50	1.4	55	50/50
6	50WL 25-25-4	25	6.9	25	2880	4	48	2.0	65	50/50
7	50WL 25-32-5.5	25	6.9	32	1440	5.5	48	2.0	90	50/50
8	50WL 25-36-7.5	25	6.9	36	1440	7.5	48	2.3	105	50/50
9	65WL 30-10-2.2	30	8.3	10	1420	2.2	62	2.5	55	65/65
10	65WL 30-15-3	30	8.3	15	1420	3	62	2.6	65	65/65
11	65WL 30-22-4	30	8.3	22	1440	4	52	2.6	75	65/65
12	65WL 30-30-5.5	30	8.3	30	1440	5.5	52	2.8	100	65/65
13	65WL 30-35-7.5	30	8.3	35	1440	7.5	50	2.8	115	65/65
14	80WL 50-8-2.2	50	13.9	8	1420	2.2	60	1.3	65	80/80
15	80WL 50-10-3	50	13.9	10	1420	3	60	1.3	75	80/80
16	80WL 50-15-4	50	13.9	15	1440	4	58	1.4	85	80/80
17	80WL 50-20-5.5	50	13.9	20	1440	5.5	55	1.2	110	80/80
18	80WL 50-25-7.5	50	13.9	25	1440	7.5	55	1.2	125	80/80
19	80WL 50-35-11	50	13.9	35	2900	11	55	1.8	180	80/80
20	80WL 50-40-15	50	13.9	40	2900	15	52	1.8	205	80/80
21	100WL 80-7-3	80	22.2	7	1420	3	64	1.6	85	100/100
22	100WL 80-10-4	80	22.2	10	1440	4	64	1.6	95	100/100
23	100WL 80-13-5.5	80	22.2	13	1440	5.5	64	1.6	120	100/100
24	100WL 80-18-7.5	80	22.2	18	1440	7.5	64	1.6	135	100/100
25	100WL 80-24-11	80	22.2	24	2900	11	64	1.8	190	100/100
26	100WL 80-32-15	80	22.2	32	2900	15	58	1.8	215	100/100
27	100WL 80-36-18.5	80	22.2	36	2900	18.5	55	1.8	280	100/100
28	100WL 80-40-22	80	22.2	40	2900	22	55	1.8	290	100/100
29	150WL 150-7-5.5	150	41.7	7	1440	5.5	72	2.5	130	150/150
30	150WL 150-10-7.5	150	41.7	10	1440	7.5	72	1.5	150	150/150
31	150WL 150-15-11	150	41.7	15	1460	11	72	2.7	215	150/150
32	150WL 150-20-15	150	41.7	20	1460	15	68	2.7	240	150/150
33	150WL 150-25-18.5	150	41.7	25	1470	18.5	68	1.6	300	150/150
34	150WL 150-30-22	150	41.7	30	1470	22	65	1.6	320	150/150
35	150WL 150-40-30	150	41.7	40	1470	30	65	1.6	580	150/150
36	150WL 150-45-37	150	41.7	45	1470	37	62	1.6	650	150/150
37	150WL 150-50-45	150	41.7	50	1470	45	62	1.6	750	150/150
38	150WL 100-60-55	100	27.8	60	1470	55	60	1.6	850	150/150
39	200WL 300-7-11	300	83.3	7	1460	11	74	2.5	280	200/200
40	200WL 300-10-15	300	83.3	10	1460	15	74	2.5	300	200/200
41	200WL 300-13-18.5	300	83.3	13	1470	18.5	68	2.5	370	200/200
42	200WL 300-15-22	300	83.3	15	1470	22	68	2.5	380	200/200
43	200WL 300-20-30	300	83.3	20	980	30	67	2.5	650	200/200
44	200WL 300-25-37	300	83.3	25	980	37	67	2.5	720	200/200

WL系列泵性能参数表 WL series pump performance table

序号 No.	型号 Model	流量 Capacity		扬程 Head (m)	转速 Speed (r/min)	功率 Power (kW)	效率 Eff. (%)	汽蚀余量 (NPSH)r (m)	重量 Weight (kg)	排出口径/吸入口径 Outlet caliber/Inlet caliber (mm)
		(m ³ /h)	(L/s)							
45	200WL 400-27-45	400	111.1	27	1470	45	74	3.0	850	200/200
46	200WL 400-34-55	400	111.1	34	1470	55	74	3.0	950	200/200
47	200WL 400-40-75	400	111.1	40	1470	75	70.5	4.0	1300	200/200
48	200WL 400-48-90	400	111.1	48	1470	90	70.5	4.0	1420	200/200
49	250WL 400-7-15	400	111.1	7	1460	15	69	3.0	450	250/250
50	250WL 400-10-18.5	400	111.1	10	1470	18.5	75	3.0	550	250/250
51	250WL 400-13-22	400	111.1	13	1470	22	73	3.0	580	250/250
52	250WL 500-10-30	500	138.9	10	980	30	72	3.4	700	250/250
53	250WL 500-16-37	500	138.9	16	980	37	72	3.4	780	250/250
54	250WL 500-20-45	500	138.9	20	980	45	72	3.4	1050	250/250
55	250WL 500-25-55	500	138.9	25	980	55	74	3.4	1115	250/250
56	250WL 600-28-75	600	166.7	28	1480	75	73	4.0	1480	250/250
57	250WL 600-34-90	600	166.7	34	1480	90	73	4.0	1580	250/250
58	250WL 600-40-110	600	166.7	40	1480	110	70	6.7	1650	250/250
59	250WL 600-50-132	600	166.7	50	1480	132	70	6.7	1710	250/250
60	300WL 600-6-18.5	600	166.7	6	1470	18.5	65	3.0	650	300/300
61	300WL 600-7-22	600	166.7	7	1470	22	65	3.0	660	300/300
62	300WL 700-11-30	700	194.4	11	980	30	78	4.8	780	300/300
63	300WL 700-14-37	700	194.4	14	980	37	78	4.8	880	300/300
64	300WL 700-16-45	700	194.4	16	980	45	78	4.8	1150	300/300
65	300WL 700-19-55	700	194.4	19	980	55	75	4.8	1215	300/300
66	300WL 1000-20-75	1000	277.8	20	990	75	82	5.6	1530	300/300
67	300WL 1000-24-90	1000	277.8	24	990	90	82	5.6	1650	300/300
68	300WL 1000-28-110	1000	277.8	28	990	110	82	6.4	1720	300/300
69	300WL 1000-35-132	1000	277.8	35	1480	132	80	6.4	1800	300/300
70	350WL 1200-6-30	1200	333.3	6	730	30	72	5.9	850	350/400
71	350WL 1200-8-37	1200	333.3	8	740	37	75	5.9	950	350/400
72	350WL 1100-10-45	1100	305.6	10	740	45	70	5.9	1250	350/400
73	350WL 1100-12-55	1100	305.6	12	740	55	71	5.9	1320	350/400
74	350WL 1100-16-75	1100	305.6	16	990	75	75	6.4	1650	350/400
75	350WL 1100-20-90	1100	305.6	20	990	90	75	6.4	1770	350/400
76	350WL 1100-25-110	1100	305.6	25	980	110	76	6.4	1840	350/400
77	350WL 1100-30-132	1100	305.6	30	980	132	75	6.4	1920	350/400
78	350WL 1100-36-160	1100	305.6	36	980	160	75	6.4	2700	350/400
79	400WL 1500-5-30	1500	416.7	5	730	30	72	5.5	960	400/400
80	400WL 1500-6-37	1500	416.7	6	740	37	72	5.5	1020	400/400
81	400WL 1500-8-45	1500	416.7	8	740	45	80	5.5	1350	400/400
82	400WL 1500-10-55	1500	416.7	10	740	55	82	5.5	1470	400/400
83	400WL 1500-12-75	1500	416.7	12	990	75	78	6.5	1740	400/400
84	400WL 1500-15-90	1500	416.7	15	990	90	78	6.5	1860	400/400
85	400WL 1500-18-110	1500	416.7	18	990	110	78	6.5	1930	400/400
86	400WL 1500-22-132	1500	416.7	22	990	132	75	6.5	2020	400/400
87	400WL 2000-16-132	2000	555.6	16	990	132	80	6.5	2020	400/400
88	400WL 2000-20-160	2000	555.6	20	990	160	80	6.7	2750	400/400

WL系列泵性能参数表 WL series pump performance table

序号 No.	型号 Model	流量 Capacity		扬程 Head (m)	转速 Speed (r/min)	功率 Power (kW)	效率 Eff. (%)	汽蚀余量 (NPSH)r (m)	重量 Weight (kg)	排出口径/吸入口径 Outlet caliber/Inlet caliber (mm)
		(m ³ /h)	(L/s)							
89	400WL 2000-23-185	2000	555.6	23	990	185	80	5.9	2800	400/400
90	400WL 2000-25-200	2000	555.6	25	740	200	80	5.9	2850	400/400
91	400WL 2000-28-220	2000	555.6	28	740	220	80	5.9	3050	400/400
92	400WL 2000-32-250	2000	555.6	32	740	250	80	5.9	3250	400/400
93	400WL 2000-36-280	2000	555.6	36	740	280	80	6.5	3450	400/400
94	450WL 2200-10-90	2200	611.1	10	990	90	72	6.5	1920	450/450
95	450WL 2200-12-110	2200	611.1	12	990	110	72	6.5	1990	450/450
96	450WL 2200-15-132	2200	611.1	15	990	132	75	5.6	2070	450/450
97	500WL 2000-7-55	2000	555.6	7	740	55	76	6.4	1950	500/500
98	500WL 2200-8-75	2200	611.1	8	740	75	70	6.4	2150	500/500
99	500WL 3000-11-132	3000	833.3	11	745	132	75	5.9	2210	500/500
100	500WL 3000-13-160	3000	833.3	13	745	160	75	5.9	2900	500/500
101	500WL 3000-15-185	3000	833.3	15	745	185	70	5.9	2950	500/500
102	500WL 3000-16-200	3000	833.3	16	745	200	72	5.9	3000	500/500
103	500WL 3000-18-220	3000	833.3	18	745	220	75	6.4	3200	500/500
104	500WL 3000-21-250	3000	833.3	21	745	250	77	6.4	3400	500/500
105	500WL 3000-24-280	3000	833.3	24	745	280	77	6.4	3600	500/500
106	600WL 2500-5-55	2500	694.4	5	590	55	72	6.4	2100	600/600
107	600WL 2500-7-75	2500	694.4	7	590	75	75	6.4	2315	600/600
108	600WL 2500-9-90	2500	694.4	9	590	90	75	6.9	2425	600/600
109	600WL 3000-8-110	3000	833.3	8	590	110	75	6.9	2900	600/600
110	600WL 3000-10-132	3000	833.3	10	590	132	75	6.9	3000	600/600
111	600WL 4000-10-160	4000	1111.1	10	745	160	75	7.1	3000	600/600
112	600WL 4000-11-185	4000	1111.1	11	745	185	75	7.1	3050	600/600
113	600WL 4000-12-200	4000	1111.1	12	745	200	72	7.1	3100	600/600
114	600WL 4000-14-220	4000	1111.1	14	745	220	75	7.1	3300	600/600
115	600WL 4000-16-250	4000	1111.1	16	745	250	78	7.1	3500	600/600
116	600WL 4000-18-280	4000	1111.1	18	745	280	77	7.1	3750	600/600
117	600WL 4000-20-315	4000	1111.1	20	740	315	80	6.7	4000	600/600
118	700WL 6000-8-200	6000	1666.7	8	590	200	81	7.6	4500	700/700
119	700WL 6000-9-220	6000	1666.7	9	590	220	81	7.6	4690	700/700
120	700WL 6000-10-250	6000	1666.7	10	590	250	81	7.6	4810	700/700
121	700WL 6000-11-280	6000	1666.7	11	590	280	81	7.6	5100	700/700
122	700WL 6000-13-315	6000	1666.7	13	590	315	81	7.6	5450	700/700
123	700WL 7500-13-400	7500	2083.3	13	590	400	81	7.8	5600	700/700
124	700WL 7500-18-560	7500	2083.3	18	590	560	81	7.8	5980	700/700
125	800WL 7500-9-280	7500	2083.3	9	590	280	81	7.8	5400	800/900
126	800WL 10000-7-315	10000	2777.8	7	420	315	81	8.0	5700	800/900
127	800WL 11000-8-355	11000	3055.6	8	420	355	81	8.1	5980	800/900
128	800WL 12000-9-400	12000	3333.3	9	420	400	81	8.7	6100	800/900
129	800WL 12000-11-560	12000	3333.3	11	420	560	82	8.7	6500	800/900
130	800WL 12000-13-630	12000	3333.3	13	420	630	83	8.7	6700	800/900
131	800WL 12000-15-710	12000	3333.3	15	420	710	83	8.7	7100	800/900
132	900WL 11000-6-315	11000	3055.6	6	420	315	76	8.1	6200	900/1000

WL(I)型立式排污泵安装尺寸图 WL(I) type vertical sewage pump dimension figure

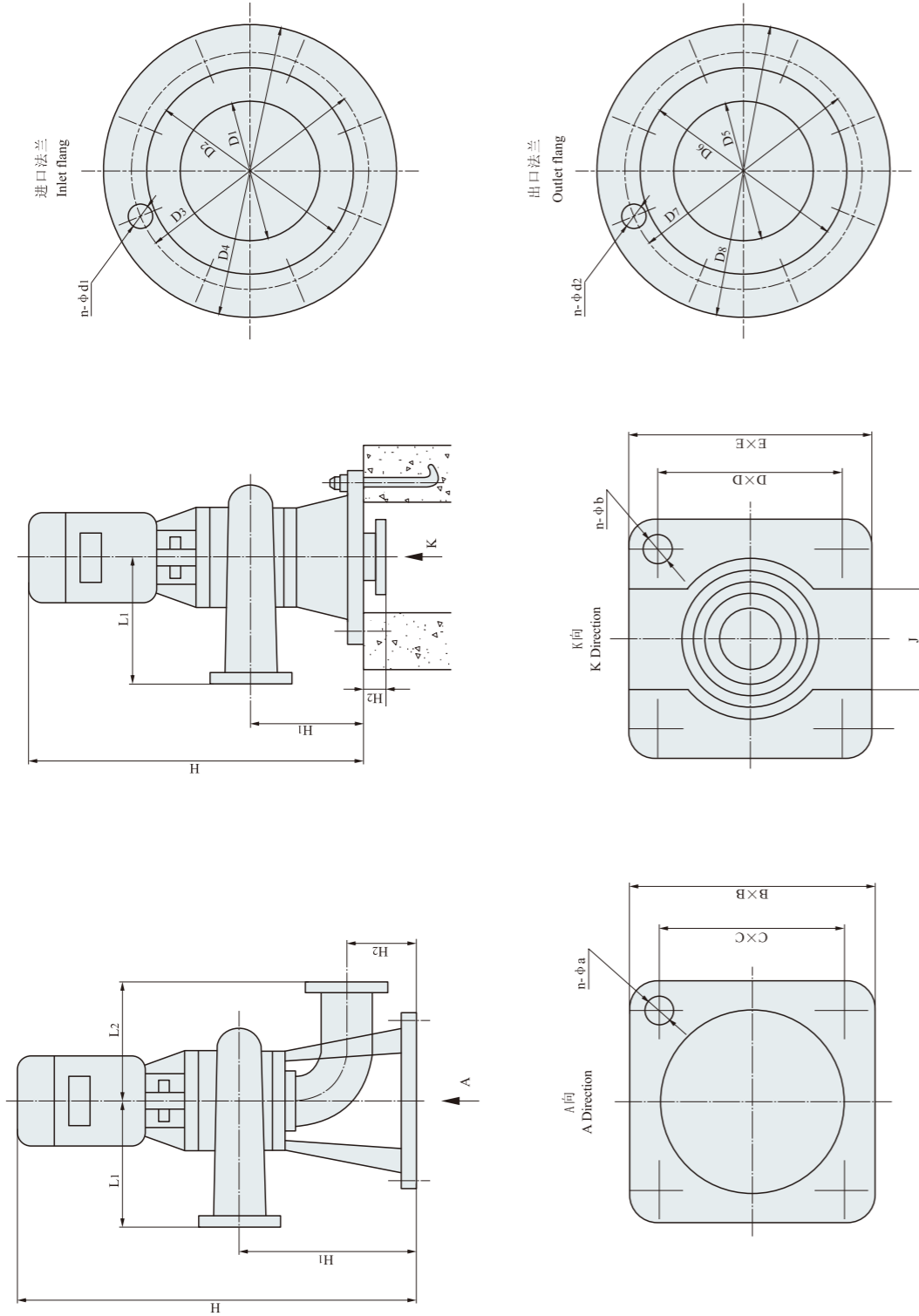

WL(I)型立式排污泵安装尺寸表 WL(I) type vertical sewage pump dimension table

序号 No.	型号 Model	进口法兰 Inlet flange						出口法兰 Outlet flange				L1	弯管式进口 Inlet of elbow						直管式进口 Inlet of straight							
		D1	D2	D3	D4	n-φd1	D5	D6	D7	D8	n-φd2		H1	H2	H	L2	C×C	B×B	n-φa	D×D	E×E	n-φb	H1	H2	H	J
1	50WL 15-8-0.75	50	90	110	140	4-φ13.5	50	90	110	140	4-φ13.5	200	260	90	595	180	250×250	300×300	4-φ15	250×250	300×300	4-φ15	130	40	465	100
2	50WL 15-12-1.1	50	90	110	140	4-φ13.5	50	90	110	140	4-φ13.5	200	260	90	595	180	250×250	300×300	4-φ15	250×250	300×300	4-φ15	130	40	465	100
3	50WL 15-16-1.5	50	90	110	140	4-φ13.5	50	90	110	140	4-φ13.5	200	260	90	610	180	250×250	300×300	4-φ15	250×250	300×300	4-φ15	130	40	480	100
4	50WL 15-22-2.2	50	90	110	140	4-φ13.5	50	90	110	140	4-φ13.5	200	260	90	635	180	250×250	300×300	4-φ15	250×250	300×300	4-φ15	130	40	505	100
5	50WL 15-30-3	50	90	110	140	4-φ13.5	50	90	110	140	4-φ13.5	225	265	90	685	180	250×250	300×300	4-φ15	250×250	300×300	4-φ15	135	40	555	100
6	50WL 15-25-4	50	90	110	140	4-φ13.5	50	90	110	140	4-φ13.5	225	265	90	705	180	250×250	300×300	4-φ15	250×250	300×300	4-φ15	135	40	575	100
7	50WL 25-32-5.5	50	90	110	140	4-φ13.5	50	90	110	140	4-φ13.5	280	280	90	860	180	250×250	300×300	4-φ15	250×250	300×300	4-φ15	150	40	730	100
8	50WL 25-36-7.5	50	90	110	140	4-φ13.5	50	90	110	140	4-φ13.5	280	280	90	860	180	250×250	300×300	4-φ15	250×250	300×300	4-φ15	150	40	730	100
9	65WL 30-10-2.2	65	110	130	160	4-φ13.5	65	110	130	160	4-φ13.5	250	280	100	705	180	265×265	305×305	4-φ15	265×265	305×305	4-φ15	140	40	565	120
10	65WL 30-15-3	65	110	130	160	4-φ13.5	65	110	130	160	4-φ13.5	250	280	100	705	180	265×265	305×305	4-φ15	265×265	305×305	4-φ15	140	40	565	120
11	65WL 30-22-4	65	110	130	160	4-φ13.5	65	110	130	160	4-φ13.5	280	280	100	725	180	265×265	305×305	4-φ15	265×265	305×305	4-φ15	140	40	585	120
12	65WL 30-30-5.5	65	110	130	160	4-φ13.5	65	110	130	160	4-φ13.5	280	280	100	860	180	265×265	305×305	4-φ15	265×265	305×305	4-φ15	140	40	720	120
13	65WL 30-35-7.5	65	110	130	160	4-φ13.5	65	110	130	160	4-φ13.5	280	280	100	860	180	265×265	305×305	4-φ15	265×265	305×305	4-φ15	140	40	720	120
14	80WL 50-8-2.2	80	128	150	190	4-φ17.5	80	128	150	190	4-φ17.5	280	350	110	785	220	320×320	380×380	4-φ20	320×320	380×380	4-φ20	185	55	620	150
15	80WL 50-10-3	80	128	150	190	4-φ17.5	80	128	150	190	4-φ17.5	280	350	110	785	220	320×320	380×380	4-φ20	320×320	380×380	4-φ20	185	55	620	150
16	80WL 50-15-4	80	128	150	190	4-φ17.5	80	128	150	190	4-φ17.5	280	350	110	805	220	320×320	380×380	4-φ20	320×320	380×380	4-φ20	185	55	640	150
17	80WL 50-20-5.5	80	128	150	190	4-φ17.5	80	128	150	190	4-φ17.5	300	355	110	860	220	320×320	380×380	4-φ20	320×320	380×380	4-φ20	190	55	695	150
18	80WL 50-25-7.5	80	128	150	190	4-φ17.5	80	128	150	190	4-φ17.5	300	355	110	900	220	320×320	380×380	4-φ20	320×320	380×380	4-φ20	190	55	735	150
19	80WL 50-35-11	80	128	150	190	4-φ17.5	80	128	150	190	4-φ17.5	280	335	110	985	220	320×320	380×380	4-φ20	320×320	380×380	4-φ20	170	55	820	150
20	80WL 50-40-15	80	128	150	190	4-φ17.5	80	128	150	190	4-φ17.5	280	335	110	985	220	320×320	380×380	4-φ20	320×320	380×380	4-φ20	170	55	820	150
21	100WL 80-7-3	100	148	170	210	4-φ17.5	100	148	170	210	4-φ17.5	280	350	120	785	220	320×320	380×380	4-φ20	320×320	380×380	4-φ20	180	50	615	180
22	100WL 80-10-4	100	148	170	210	4-φ17.5	100	148	170	210	4-φ17.5	280	350	120	805	220	320×320	380×380	4-φ20	320×320	380×380	4-φ20	180	50	635	180

WL(I)型立式排污泵安装尺寸表 WL(I) type vertical sewage pump dimension table

序号 No.	型号 Model	进口法兰 Inlet flange				出口法兰 Outlet flange				L1	弯管式进口 Inlet of elbow				直管式进口 Inlet of straight											
		D1	D2	D3	D4	n-φd1	D5	D6	D7		D8	n-φd2	H1	H2	H	L2	C×C	B×B	n-φa	D×D	E×E	n-φb	H1	H2	H	J
23	100WL 80-13-5.5	100	148	170	210	4-φ17.5	100	148	170	210	4-φ17.5	320	365	120	900	220	320×320	380×380	4-φ20	320×320	380×380	4-φ20	195	50	730	180
24	100WL 80-18-7.5	100	148	170	210	4-φ17.5	100	148	170	210	4-φ17.5	320	365	120	900	220	320×320	380×380	4-φ20	320×320	380×380	4-φ20	195	50	730	180
25	100WL 80-24-11	100	148	170	210	4-φ17.5	100	148	170	210	4-φ17.5	320	345	120	985	220	320×320	380×380	4-φ20	320×320	380×380	4-φ20	175	50	815	180
26	100WL 80-32-15	100	148	170	210	4-φ17.5	100	148	170	210	4-φ17.5	320	345	120	985	220	320×320	380×380	4-φ20	320×320	380×380	4-φ20	175	50	815	180
27	100WL 80-36-18.5	100	148	170	210	4-φ17.5	100	148	170	210	4-φ17.5	320	345	120	1040	220	320×320	380×380	4-φ20	320×320	380×380	4-φ20	175	50	870	180
28	100WL 80-40-22	100	148	170	210	4-φ17.5	100	148	170	210	4-φ17.5	320	345	120	1040	220	320×320	380×380	4-φ20	320×320	380×380	4-φ20	175	50	870	180
29	150WL 150-7-5.5	150	202	225	265	8-φ17.5	150	202	225	265	8-φ17.5	350	460	160	1025	270	400×400	480×480	4-φ20	400×400	480×480	4-φ20	240	60	805	200
30	150WL 150-10-7.5	150	202	225	265	8-φ17.5	150	202	225	265	8-φ17.5	350	460	160	1025	270	400×400	480×480	4-φ20	400×400	480×480	4-φ20	240	60	805	200
31	150WL 150-15-11	150	202	225	265	8-φ17.5	150	202	225	265	8-φ17.5	350	430	160	1145	270	400×400	480×480	4-φ20	400×400	480×480	4-φ20	210	60	925	200
32	150WL 150-20-15	150	202	225	265	8-φ17.5	150	202	225	265	8-φ17.5	350	430	160	1220	270	400×400	480×480	4-φ20	400×400	480×480	4-φ20	210	60	1000	200
33	150WL 150-25-18.5	150	202	225	265	8-φ17.5	150	202	225	265	8-φ17.5	400	470	160	1255	270	400×400	480×480	4-φ20	400×400	480×480	4-φ20	250	60	1035	200
34	150WL 150-30-22	150	202	225	265	8-φ17.5	150	202	225	265	8-φ17.5	400	470	160	1295	270	400×400	480×480	4-φ20	400×400	480×480	4-φ20	250	60	1075	200
35	150WL 150-40-30	150	202	225	265	8-φ17.5	150	202	225	265	8-φ17.5	400	470	160	1365	270	400×400	480×480	4-φ20	400×400	480×480	4-φ20	250	60	1145	200
36	150WL 150-45-37	150	202	225	265	8-φ17.5	150	202	225	265	8-φ17.5	450	475	160	1385	270	400×400	480×480	4-φ20	400×400	480×480	4-φ20	255	60	1165	200
37	150WL 150-50-45	150	202	225	265	8-φ17.5	150	202	225	265	8-φ17.5	450	475	160	1410	270	400×400	480×480	4-φ20	400×400	480×480	4-φ20	255	60	1190	200
38	150WL 100-60-55	150	202	225	265	8-φ17.5	150	202	225	265	8-φ17.5	450	475	160	1495	270	400×400	480×480	4-φ20	400×400	480×480	4-φ20	255	60	1275	200
39	200WL 300-7-11	200	258	280	320	8-φ17.5	200	258	280	320	8-φ17.5	400	550	200	1240	350	520×520	600×600	4-φ25	580×580	680×680	4-φ25	270	80	960	280
40	200WL 300-10-15	200	258	280	320	8-φ17.5	200	258	280	320	8-φ17.5	400	550	200	1295	350	520×520	600×600	4-φ25	580×580	680×680	4-φ25	270	80	1015	280
41	200WL 300-13-18.5	200	258	280	320	8-φ17.5	200	258	280	320	8-φ17.5	400	555	200	1345	350	520×520	600×600	4-φ25	580×580	680×680	4-φ25	275	80	1065	280
42	200WL 300-15-22	200	258	280	320	8-φ17.5	200	258	280	320	8-φ17.5	400	555	200	1385	350	520×520	600×600	4-φ25	580×580	680×680	4-φ25	275	80	1105	280
43	200WL 300-20-30	200	258	280	320	8-φ17.5	200	258	280	320	8-φ17.5	500	595	200	1660	350	520×520	600×600	4-φ25	580×580	680×680	4-φ25	315	80	1380	280
44	200WL 300-25-37	200	258	280	320	8-φ17.5	200	258	280	320	8-φ17.5	500	595	200	1785	350	520×520	600×600	4-φ25	580×580	680×680	4-φ25	315	80	1505	280

WL(I)型立式排污泵安装尺寸表 WL(I) type vertical sewage pump dimension table

序号 No.	型号 Model	进口法兰 Inlet flange				出口法兰 Outlet flange				L1	弯管式进口 Inlet of elbow				直管式进口 Inlet of straight											
		D1	D2	D3	D4	n-φd1	D5	D6	D7		D8	n-φd2	H1	H2	H	L2	C×C	B×B	N-φa	D×D	E×E	N-φb	H1	H2	H	J
45	200WL 400-27-45	200	258	280	320	8-φ17.5	200	258	280	320	8-φ17.5	500	595	200	1660	350	520×520	600×600	4-φ25	580×580	680×680	4-φ25	315	80	1380	280
46	200WL 400-34-55	200	258	280	320	8-φ17.5	200	258	280	320	8-φ17.5	500	595	200	1785	350	520×520	600×600	4-φ25	580×580	680×680	4-φ25	315	80	1505	280
47	200WL 400-40-75	200	258	280	320	8-φ17.5	200	258	280	320	8-φ17.5	500	595	200	1855	350	520×520	600×600	4-φ25	580×580	680×680	4-φ25	315	80	1575	280
48	200WL 400-48-90	200	258	280	320	8-φ17.5	200	258	280	320	8-φ17.5	500	595	200	1905	350	520×520	600×600	4-φ25	580×580	680×680	4-φ25	315	80	1625	280
49	250WL 400-7-15	250	312	335	375	12-φ17.5	250	312	335	375	12-φ17.5	420	585	225	1370	350	520×520	600×600	4-φ25	580×580	680×680	4-φ25	285	100	1070	330
50	250WL 400-10-18.5	250	312	335	375	12-φ17.5	250	312	335	375	12-φ17.5	420	585	225	1405	350	520×520	600×600	4-φ25	580×580	680×680	4-φ25	285	100	1105	330
51	250WL 400-13-22	250	312	335	375	12-φ17.5	250	312	335	375	12-φ17.5	420	585	225	1445	350	520×520	600×600	4-φ25	580×580	680×680	4-φ25	285	100	1145	330
52	250WL 500-10-30	250	312	335	375	12-φ17.5	250	312	335	375	12-φ17.5	550	620	225	1585	350	520×520	600×600	4-φ25	580×580	680×680	4-φ25	320	100	1285	330
53	250WL 500-16-37	250	312	335	375	12-φ17.5	250	312	335	375	12-φ17.5	550	620	225	1670	350	520×520	600×600	4-φ25	580×580	680×680	4-φ25	320	100	1370	330
54	250WL 500-20-45	250	312	335	375	12-φ17.5	250	312	335	375	12-φ17.5	550	620	225	1740	350	520×520	600×600	4-φ25	580×580	680×680	4-φ25	320	100	1440	330
55	250WL 500-25-55	250	312	335	375	12-φ17.5	250	312	335	375	12-φ17.5	550	620	225	1790	350	520×520	600×600	4-φ25	580×580	680×680	4-φ25	320	100	1490	330
56	250WL 600-28-75	250	312	335	375	12-φ17.5	250	312	335	375	12-φ17.5	550	620	225	1740	350	520×520	600×600	4-φ25	580×580	680×680	4-φ25	320	100	1440	330
57	250WL 600-34-90	250	312	335	375	12-φ17.5	250	312	335	375	12-φ17.5	550	620	225	1790	350	520×520	600×600	4-φ25	580×580	680×680	4-φ25	320	100	1490	330
58	250WL 600-40-110	250	312	335	375	12-φ17.5	250	312	335	375	12-φ17.5	550	620	225	2180	350	520×520	600×600	4-φ25	580×580	680×680	4-φ25	320	100	1880	330
59	250WL 600-50-132	250	312	335	375	12-φ17.5	250	312	335	375	12-φ17.5	550	620	225	2300	350	520×520	600×600	4-φ25	580×580	680×680	4-φ25	320	100	2000	330
60	300WL 600-6-18.5	300	365	395	440	12-φ22	300	365	395	440	12-φ22	480	695	275	1525	350	520×520	600×600	4-φ25	680×680	760×760	4-φ25	345	100	1175	400
61	300WL 600-7-22	300	365	395	440	12-φ22	300	365	395	440	12-φ22	480	695	275	1565	350	520×520	600×600	4-φ25	680×680	760×760	4-φ25	345	100	1215	400
62	300WL 700-11-30	300	365	395	440	12-φ22	300	365	395	440	12-φ22	600	750	270	2300	450	620×620	720×720	4-φ40	680×680	760×760	4-φ25	320	100	2000	400
63	300WL 700-14-37	300	365	395	440	12-φ22	300	365	395	440	12-φ22	600	750	270	2300	450	620×620	720×720	4-φ40	680×680	760×760	4-φ25	320	100	2000	400
64	300WL 700-16-45	300	365	395	440	12-φ22	300	365	395	440	12-φ22	600	750	270	2300	450	620×620	720×720	4-φ40	680×680	760×760	4-φ25	320	100	2000	400
65	300WL 700-19-55	300	365	395	440	12-φ22	300	365	395	440	12-φ22	600	750	270	2300	450	620×620	720×720	4-φ40	680×680	760×760	4-φ25	320	100	2000	400

WL(II)型立式排污泵安装尺寸图 WL(II) type vertical sewage pump dimension figure

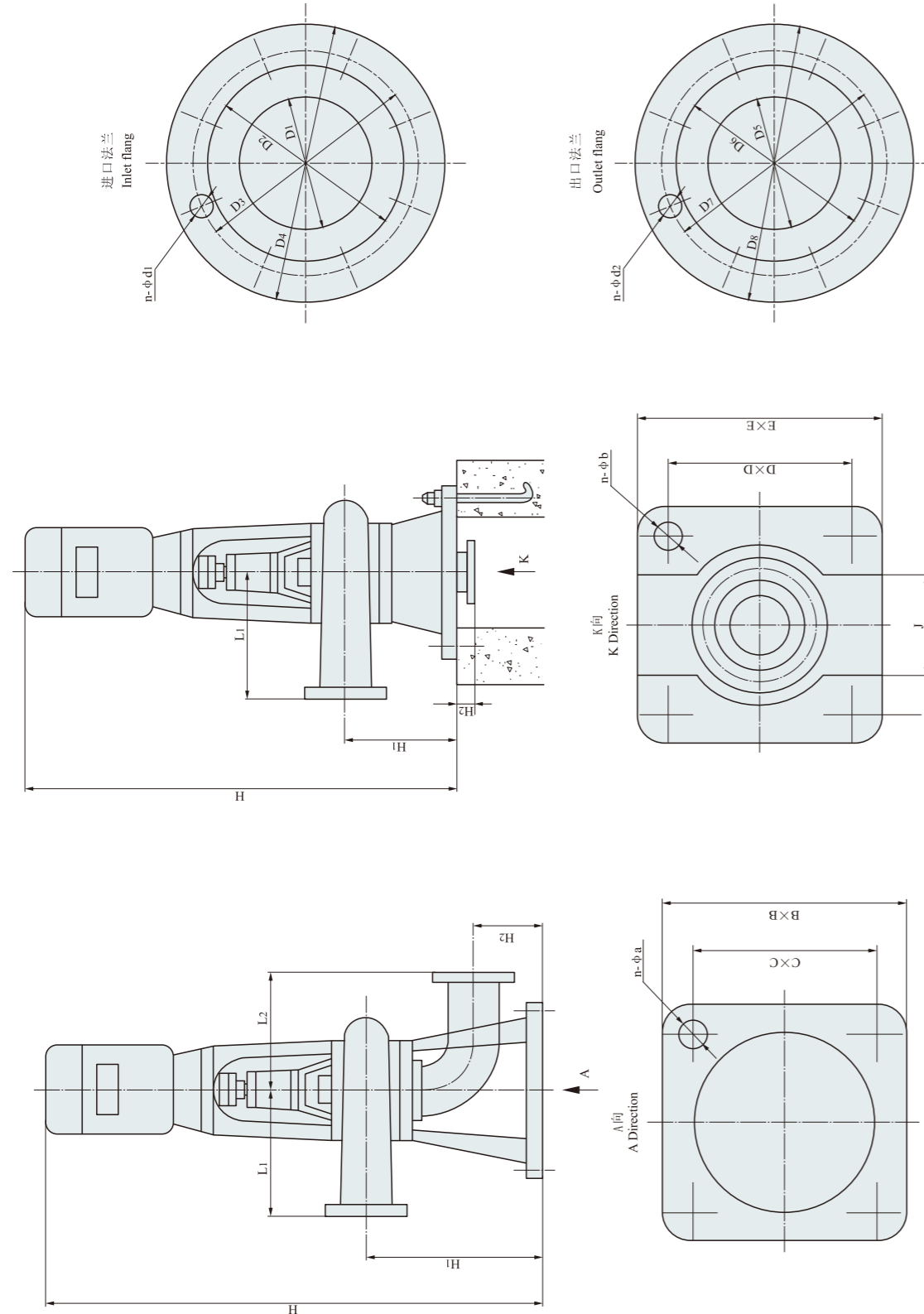

WL(II)型立式排污泵安装尺寸表 WL(II) type vertical sewage pump dimension table

序号 No.	型号 Model	进口法兰 Inlet flange				出口法兰 Outlet flange				弯管式进口 Inlet of elbow				直管式进口 Inlet of straight												
		D1	D2	D3	D4	N-φd1	D5	D6	D7	D8	N-φd2	L1	H1	H2	H	L2	C×C	B×B	N-φa	D×D	E×E	N-φb	H1	H2	H	J
1	200WL 300-20-30	200	258	280	320	8-φ175	200	258	280	320	8-φ175	500	570	200	2760	350	520×520	600×600	4-φ25	580×580	680×680	4-φ25	315	80	2180	280
2	200WL 300-25-37	200	258	280	320	8-φ175	200	258	280	320	8-φ175	500	570	200	2885	350	520×520	600×600	4-φ25	580×580	680×680	4-φ25	315	80	2605	280
3	200WL 400-27-45	200	258	280	320	8-φ175	200	258	280	320	8-φ175	500	570	200	2760	350	520×520	600×600	4-φ25	580×580	680×680	4-φ25	315	80	2480	280
4	200WL 400-34-55	200	258	280	320	8-φ175	200	258	280	320	8-φ175	500	570	200	2885	350	520×520	600×600	4-φ25	580×580	680×680	4-φ25	315	80	2605	280
5	200WL 400-40-75	200	258	280	320	8-φ175	200	258	280	320	8-φ175	500	570	200	2955	350	520×520	600×600	4-φ25	580×580	680×680	4-φ25	315	80	2675	280
6	200WL 400-48-90	200	258	280	320	8-φ175	200	258	280	320	8-φ175	500	570	200	3005	350	520×520	600×600	4-φ25	580×580	680×680	4-φ25	315	80	2725	280
7	250WL 500-10-30	250	312	335	375	12-φ175	250	312	335	375	12-φ175	550	620	225	2685	350	520×520	600×600	4-φ25	580×580	680×680	4-φ25	320	100	2385	330
8	250WL 500-16-37	250	312	335	375	12-φ175	250	312	335	375	12-φ175	550	620	225	2770	350	520×520	600×600	4-φ25	580×580	680×680	4-φ25	320	100	2470	330
9	250WL 500-20-45	250	312	335	375	12-φ175	250	312	335	375	12-φ175	550	620	225	2840	350	520×520	600×600	4-φ25	580×580	680×680	4-φ25	320	100	2540	330
10	250WL 500-25-55	250	312	335	375	12-φ175	250	312	335	375	12-φ175	550	620	225	2905	350	520×520	600×600	4-φ25	580×580	680×680	4-φ25	320	100	2605	330
11	250WL 600-28-75	250	312	335	375	12-φ175	250	312	335	375	12-φ175	550	620	225	2940	350	520×520	600×600	4-φ25	580×580	680×680	4-φ25	320	100	2640	330
12	250WL 600-34-90	250	312	335	375	12-φ175	250	312	335	375	12-φ175	550	620	225	2990	350	520×520	600×600	4-φ25	580×580	680×680	4-φ25	320	100	2690	330
13	250WL 600-40-110	250	312	335	375	12-φ175	250	312	335	375	12-φ175	550	620	225	3280	350	520×520	600×600	4-φ25	580×580	680×680	4-φ25	320	100	2980	330
14	250WL 600-50-132	250	312	335	375	12-φ175	250	312	335	375	12-φ175	550	620	225	3400	350	520×520	600×600	4-φ25	580×580	680×680	4-φ25	320	100	3100	330
15	300WL 700-11-30	300	365	395	440	12-φ22	300	365	395	440	12-φ22	600	750	270	2900	450	620×620	720×720	4-φ40	680×680	760×760	4-φ25	320	100	2600	400
16	300WL 700-14-37	300	365	395	440	12-φ22	300	365	395	440	12-φ22	600	750	270	2900	450	620×620	720×720	4-φ40	680×680	760×760	4-φ25	320	100	2600	400
17	300WL 700-16-45	300	365	395	440	12-φ22	300	365	395	440	12-φ22	600	750	270	2900	450	620×620	720×720	4-φ40	680×680	760×760	4-φ25	320	100	2600	400
18	300WL 700-19-55	300	365	395	440	12-φ22	300	365	395	440	12-φ22	600	750	270	2900	450	620×620	720×720	4-φ40	680×680	760×760	4-φ25	320	100	2600	400
19	300WL 1000-20-75	300	365	395	440	12-φ22	300	365	395	440	12-φ22	700	805	270	2940	350	520×520	600×600	4-φ25	680×680	760×760	4-φ25	320	100	2640	400
20	300WL 1000-24-90	300	365	395	440	12-φ22	300	365	395	440	12-φ22	700	805	270	2990	350	520×520	600×600	4-φ25	680×680	760×760	4-φ25	320	100	2690	400
21	300WL 1000-28-110	300	365	395	440	12-φ22	300	365	395	440	12-φ22	700	805	270	3280	350	520×520	600×600	4-φ25	680×680	760×760	4-φ25	320	100	2980	400
22	300WL 1000-35-132	300	365	395	440	12-φ22	300	365	395	440	12-φ22	700	805	270	3400	350	520×520	600×600	4-φ25	680×680	760×760	4-φ25	320	100	3100	400
23	350WL 1200-6-30	400	482	515	565	16-φ26	350	415	445	490	12-φ22	650	1000	330	2900	600	1000×1000	1100×1100	4-φ50	1000×1000	1100×1100	4-φ50	620		2600	480

WL(II)型立式排污泵安装尺寸表 WL(II) type vertical sewage pump dimension table

序号 No.	型号 Model	进口法兰 Inlet flange						出口法兰 Outlet flange						弯管式进口 Inlet of elbow						直管式进口 Inlet of straight						
		D1	D2	D3	D4	N-φd1	D5	D6	D7	D8	N-φd2	L1	H1	H2	H	L2	C×C	B×B	N-φa	D×D	E×E	N-φb	H1	H2	H	J
24	350WL 1200-8-37	400	482	515	565	16-φ26	350	415	445	490	12-φ22	650	1000	330	2900	600	1000×1000	1100×1100	4-φ50	1000×1000	1100×1100	4-φ50	620	620	2600	480
25	350WL 1100-10-45	400	482	515	565	16-φ26	350	415	445	490	12-φ22	650	1000	330	2900	600	1000×1000	1100×1100	4-φ50	1000×1000	1100×1100	4-φ50	620	620	2600	480
26	350WL 1100-12-55	400	482	515	565	16-φ26	350	415	445	490	12-φ22	650	1000	330	2900	600	1000×1000	1100×1100	4-φ50	1000×1000	1100×1100	4-φ50	620	620	2600	480
27	350WL 1100-16-75	400	482	515	565	16-φ26	350	415	445	490	12-φ22	700	935	330	3255	600	1000×1000	1100×1100	4-φ50	1200×1200	1300×1300	4-φ50	620	620	2955	480
28	350WL 1100-20-90	400	482	515	565	16-φ26	350	415	445	490	12-φ22	700	935	330	3255	600	1000×1000	1100×1100	4-φ50	1200×1200	1300×1300	4-φ50	620	620	2955	480
29	350WL 1100-25-110	400	482	515	565	16-φ26	350	415	445	490	12-φ22	700	935	330	3655	600	1000×1000	1100×1100	4-φ50	1200×1200	1300×1300	4-φ50	620	620	3355	480
30	350WL 1100-30-132	400	482	515	565	16-φ26	350	415	445	490	12-φ22	700	935	330	3655	600	1000×1000	1100×1100	4-φ50	1200×1200	1300×1300	4-φ50	620	620	3355	480
31	350WL 1100-36-160	400	482	515	565	16-φ26	350	415	445	490	12-φ22	700	935	330	3655	600	1000×1000	1100×1100	4-φ50	1200×1200	1300×1300	4-φ50	620	620	3355	480
32	400WL 1500-5-30	400	482	515	565	16-φ26	400	482	515	565	16-φ26	700	1035	330	3255	600	1000×1000	1100×1100	4-φ50	1000×1000	1100×1100	4-φ50	655	655	2955	480
33	400WL 1500-6-37	400	482	515	565	16-φ26	400	482	515	565	16-φ26	700	1035	330	3255	600	1000×1000	1100×1100	4-φ50	1000×1000	1100×1100	4-φ50	655	655	2955	480
34	400WL 1500-8-45	400	482	515	565	16-φ26	400	482	515	565	16-φ26	700	1035	330	3255	600	1000×1000	1100×1100	4-φ50	1000×1000	1100×1100	4-φ50	655	655	2955	480
35	400WL 1500-10-55	400	482	515	565	16-φ26	400	482	515	565	16-φ26	700	1035	330	3255	600	1000×1000	1100×1100	4-φ50	1000×1000	1100×1100	4-φ50	655	655	2955	480
36	400WL 1500-12-75	400	482	515	565	16-φ26	400	482	515	565	16-φ26	700	1035	330	3655	600	1000×1000	1100×1100	4-φ50	1000×1000	1100×1100	4-φ50	655	655	3355	480
37	400WL 1500-15-90	400	482	515	565	16-φ26	400	482	515	565	16-φ26	700	1035	330	3655	600	1000×1000	1100×1100	4-φ50	1000×1000	1100×1100	4-φ50	655	655	3355	480
38	400WL 1500-18-110	400	482	515	565	16-φ26	400	482	515	565	16-φ26	700	1035	330	3655	600	1000×1000	1100×1100	4-φ50	1200×1200	1300×1300	4-φ50	655	655	3355	480
39	400WL 1500-22-132	400	482	515	565	16-φ26	400	482	515	565	16-φ26	700	1040	330	3655	650	1100×1100	1300×1300	4-φ50	1200×1200	1300×1300	4-φ50	655	655	3355	480
40	400WL 2000-16-132	400	482	515	565	16-φ26	400	482	515	565	16-φ26	700	1040	330	3655	600	1000×1000	1100×1100	4-φ50	1000×1000	1100×1100	4-φ50	655	655	3355	480
41	400WL 2000-20-160	400	482	515	565	16-φ26	400	482	515	565	16-φ26	700	1040	330	4005	650	1100×1100	1300×1300	4-φ50	1200×1200	1300×1300	4-φ50	655	655	3705	480
42	400WL 2000-23-185	400	482	515	565	16-φ26	400	482	515	565	16-φ26	700	1040	330	4005	650	1100×1100	1300×1300	4-φ50	1200×1200	1300×1300	4-φ50	655	655	3705	480
43	400WL 2000-25-200	400	482	515	565	16-φ26	400	482	515	565	16-φ26	650	1040	330	4005	600	1000×1000	1100×1100	4-φ50	1000×1000	1100×1100	4-φ50	655	655	3705	480
44	400WL 2000-28-220	400	482	515	565	16-φ26	400	482	515	565	16-φ26	650	1040	330	4275	600	1000×1000	1100×1100	4-φ50	1000×1000	1100×1100	4-φ50	655	655	3975	480
45	400WL 2000-32-250	400	482	515	565	16-φ26	400	482	515	565	16-φ26	650	1040	330	4275	600	1000×1000	1100×1100	4-φ50	1000×1000	1100×1100	4-φ50	655	655	3975	480
46	400WL 2000-36-280	400	482	515	565	16-φ26	400	482	515	565	16-φ26	650	1040	330	4275	600	1000×1000	1100×1100	4-φ50	1000×1000	1100×1100	4-φ50	655	655	3975	480

WL(II)型立式排污泵安装尺寸表 WL(II) type vertical sewage pump dimension table

序号 No.	型号 Model	进口法兰 Inlet flange						出口法兰 Outlet flange						弯管式进口 Inlet of elbow						直管式进口 Inlet of straight						
		D1	D2	D3	D4	N-φd1	D5	D6	D7	D8	N-φd2	L1	H1	H2	H	L2	C×C	B×B	N-φa	D×D	E×E	N-φb	H1	H2	H	J
47	450WL 2200-10-90	450	532	565	615	20-φ26	450	532	565	615	20-φ26	700	1175	550	3785	600	1000×1000	1100×1100	4-φ50	1000×1000	1100×1100	4-φ50	695	695	3485	550
48	450WL 2200-12-110	450	532	565	615	20-φ26	450	532	565	615	20-φ26	700	1175	550	3785	600	1000×1000	1100×1100	4-φ50	1000×1000	1100×1100	4-φ50	695	695	3485	550
49	450WL 2200-15-132	450	532	565	615	20-φ26	450	532	565	615	20-φ26	700	1175	550	3785	600	1000×1000	1100×1100	4-φ50	1000×1000	1100×1100	4-φ50	695	695	3485	550
50	500WL 2000-7-55	500	585	620	670	20-φ26	500	585	620	670	20-φ26	700	1375	450	4135	700	1100×1100	1200×1200	4-φ50	1100×1100	1200×1200	4-φ50	830	830	3595	600
51	500WL 2200-8-75	500	585	620	670	20-φ26	500	585	620	670	20-φ26	700	1375	450	4135	700	1100×1100	1200×1200	4-φ50	1100×1100	1200×1200	4-φ50	830	830	3595	600
52	500WL 3000-11-132	500	585	620	670	20-φ26	500	585	620	670	20-φ26	1000	1375	450	4525	700	1100×1100	1200×1200	4-φ50	1400×1400	1500×1500	4-φ50	830	830	3985	600
53	500WL 3000-13-160	500	585	620	670	20-φ26	500	585	620	670	20-φ26	1000	1375	450	4595	700	1100×1100	1200×1200	4-φ50	1400×1400	1500×1500	4-φ50	830	830	4055	600
54	500WL 3000-15-185	500	585	620	670	20-φ26	500	585	620	670	20-φ26	1000	1375	450	4595	700	1100×1100	1200×1200	4-φ50	1400×1400	1500×1500	4-φ50	830	830	4055	600
55	500WL 3000-16-200	500	585	620	670	20-φ26	500	585	620	670	20-φ26	1000	1375	450	4595	700	1100×1100	1200×1200	4-φ50	1400×1400	1500×1500	4-φ50	830	830	4055	600
56	500WL 3000-18-220	500	585	620	670	20-φ26	500	585	620	670	20-φ26	1000	1375	450	4855	700	1100×1100	1200×1200	4-φ50	1100×1100	1200×1200	4-φ50	830	830	4315	600
57	500WL 3000-21-250	500	585	620	670	20-φ26	500	585	620	670	20-φ26	1000	1375	450	4855	700	1100×1100	1200×1200	4-φ50	1100×1100	1200×1200	4-φ50	830	830	4315	600
58	500WL 3000-24-280	500	585	620	670	20-φ26	500	585	620	670	20-φ26	1000	1375	450	4855	700	1100×1100	1200×1200	4-φ50	1100×1100	1200×1200	4-φ50	830	830	4315	600
59	600WL 2500-5-55	600	685	725	785	20-φ30	600	685	725	785	20-φ30	1000	1375	450	4135	700	1100×1100	1200×1200	4-φ50	1100×1100	1200×1200	4-φ50	830	830	3595	700
60	600WL 2500-7-75	600	685	725	785	20-φ30	600	685	725	785	20-φ30	1000	1375	450	4135	700	1100×1100	1200×1200	4-φ50	1100×1100	1200×1200	4-φ50	830	830	3595	700
61	600WL 2500-9-90	600	685	725	785	20-φ30	600	685	725	785	20-φ30	1000	1375	450	4525	700	1100×1100	1200×1200	4-φ50	1100×1100	1200×1200	4-φ50	830	830	3985	700
62	600WL 3000-8-110	600	685	725	785	20-φ30	600	685	725	785	20-φ30	1000	1375	450	4525	700	1100×1100	1200×1200	4-φ50	1100×1100	1200×1200	4-φ50	830	830	3985	700
63	600WL 3000-10-132	600	685	725	785	20-φ30	600	685	725	785	20-φ30	1000	1375	450	4525	700	1100×1100	1200×1200	4-φ50	1100×1100	1200×1200	4-φ50	830	830	3985	700
64	600WL 4000-10-160	600	685	725	785	20-φ30	600	685	725	785	20-φ30	1000	1375	450	4595	700	1100×1100	1200×1200	4-φ50	1100×1100	1200×1200	4-φ50	830	830	4055	700
65	600WL 4000-11-185	600	685	725	785	20-φ30	600	685	725	785	20-φ30	1000	1375	450	4595	700	1100×1100	1200×1200	4-φ50	1100×1100	1200×1200	4-φ50	830	830	4055	700

泵的安装和使用 Installation and use

1、连接泵的管路，应另设支架，不允许将其重量加在泵体上。

2、为使用安全起见，在泵的进、出口管路上应各安装一只调节阀，并在泵的出口处安装一只压力表，以保证泵在规定工况下运行，确保泵的正常运转，提高泵的使用寿命。

3、安装时必须拧紧地脚螺栓、检查泵和电机的紧固情况和有无损伤。

4、输送高温液体时，泵座的底脚螺栓不应固定，使管路系统在热胀冷缩时，泵能与管路一起移动，以避免泵承受管路的热变形。

1、A stand should be used to connect the pipeline of the pump and do not let the weight of the pipeline supported by the pump casing.

2.For the sake of safe use, mount a regulation valve separately on both inlet and outlet pipelines of the pump and a piezometer on the outlet to ensure the pump to run under the set working conditions so as to make sure of its normal running and raise its duration.

3.In installation, tighten the foot bolts, check if both pump and motor tightened and damaged.

4.When to transport high-temperature liquids, the foot bolts on the pump foundation can not be fixed so as to let the pump able to move together with the pipeline when they are in heat-expansion and cold-shrinkage to avoid it from being deformed due to the heat from the pipeline.

泵的维护和保养 Maintenance

1、泵的进口管路必须充满液体、严禁在缺液状态和汽蚀工况下运行，以提高泵的使用寿命。

2、电泵不得长期处于低扬程状态下运行，定期、定时检查电机电流值，以防水泵因过载而烧坏电机。

3、若泵为铸铁材料时，在冬季安装应防止击破，温度特别低时，应加以保温处理。

4、泵长期运行后，应停车检查，必要时可更换易损零件、机械密封及轴承，机组大修期一般为一年。

1、The inlet pipeline of the pump must be fully filled with liquid and never let the pump running under the status of liquid-missing and under the working condition of vapour corrosion so as to enhance its duration.

2、Do not let the pump running for a long time under a low head status and periodically check the current value of the motor to prevent the motor from being burnt due overload on the pump.

3、The pump, If made of cast-iron material, should be protected to avoid it from being broken due to knocking in installation in winter and take warming work for it at a specially low temperature.

4、Stop and check the pump after it runs for a long time and, if necessary, replace the easily worn-out parts, mechanical seal and bearing. The period for the pump unit to be exhausted is one year in general.

故障原因及排除方法 Failures causes and troubleshooting

故障现象 Failure	原因分析 Causes	排除方法 Troubleshooting
流量不足或不出水 Insufficient flow or no water out	<ol style="list-style-type: none"> 1、叶轮旋转错误 Wrong direction the impeller moves in 2、阀门是否打开或完好 Valve is opened or intact 3、管道叶轮被堵 Pipeline's impeller blocked up 4、扬程过高 Too high head 5、抽送介质密度较大 Bigger density of the medium being transported 6、密封圈损坏 Seal-ring damaged 	<ol style="list-style-type: none"> 1、调整叶轮旋转方向 Adjust the direction 2、检查、维修、排除 Check, repair, remove 3、清理杂物 Make up foreign matters 4、改泵或降低扬程 Change pump or lower head 5、用水冲稀降低密度 Lower density by way of using water to make it thinner 6、更换 Replace it
运行不稳定 Unstable running	<ol style="list-style-type: none"> 1、叶轮不平衡 Impeller unbalanced 2、轴承损坏 Bearing damaged 	<ol style="list-style-type: none"> 1、送制造厂调换或校正 Replace it by returning it to the manufacturer or correct it 2、更换 Replace it
泵不能启动 Pump can not be started	<ol style="list-style-type: none"> 1、缺相 Lack of phase 2、叶轮卡住 Impeller jammed 3、定子绕组烧坏 Stator's winding burnt 	<ol style="list-style-type: none"> 1、检查电器及电路，进行修复 Check electric appliances and circuit and repair 2、排除杂物 Get rid of foreign matters 3、修理，更换绕组 Repair and replace winding
电流过大 Too heavy current	<ol style="list-style-type: none"> 1、工作电压低 Low working voltage 2、管道、叶轮被堵 Pipeline, impeller blocked up 3、抽送液体的密度或粘度较高 Higher density or viscosity of the liquid being transported 4、使用扬程过低 Too low head being used 	<ol style="list-style-type: none"> 1、调整工作电压 Adjust the voltage 2、清理管道、叶轮堵物 Make up pipeline, impeller's clogs 3、改变密度或粘度 Change density or viscosity 4、减少流量，提高扬程 Reduce flow, raise head
压力不足 Unenough pressure	<ol style="list-style-type: none"> 1、机械密封损坏或泄漏 Mechanical seal damaged or leaks 2、电缆线破损 Cable broken 	<ol style="list-style-type: none"> 1、更换 Replace it 2、更换 Replace it

管路损耗参考表 Reference table for pipeline loss

流量 Capacity(L/s)

直管摩擦损失简表(估计用)100m直管损失米数以新铸铁管为标准,旧管加倍。
Brief table for the frictional loss of a straight pipe(for evaluation),the lost meters of a 100m straight pipe takes the newly iron pipe as the standard and multiple for the old one.

管径 Pipe diameter (mm)	1	2	4	6	8	10	15	20	25	30	40	50	60	70	80	90	100	110	120	130	140	160	180	200	
25	32.7	13.0																							
38	3.5	14	55																						
50	0.8	3.1	13	29																					
65		1.6	3.2	7.1	13	20																			
75		0.4	0.8	3.3	5.9	9.6	21.6																		
100			0.23	0.8	1.3	2.1	6.8	8.6	13	19.4															
125			0.23	0.4	0.63	1.3	2.7	4.1	5.9	10.7															
150				0.16	0.26	0.58	1.1	1.6	2.3	4.2	6.4	9.4													
175					0.11	0.27	0.5	0.74	1.05	1.9	2.9	4.3	5.8	7.7	9.6										
200						0.13	0.26	0.37	0.53	0.93	1.5	2.1	2.9	3.7	4.7	6.1	7.2	8.5							
250							0.07	0.12	0.18	0.30	0.48	0.68	0.93	1.2	1.5	1.9	2.3	2.8	3.3	3.7	4.9	5.2			
300									0.07	0.12	0.19	0.27	0.37	0.49	0.61	0.76	0.9	1.1	1.3	1.5	2.0	2.4	3.0		

阀及弯管折合直管长度(每个)
The length of a straight pipe converted into from both valve and elbow(each)

种类 Variety	折合直管直径倍数 Convert into the times of the diameter of a straight pipe	备注 Remark
标准弯管 Standard elbow	12	未畅开加倍 Multiple in case of unopen
全开闸阀 Fully opened gate valve	25	
截止阀 Back valve	100	
底阀 Foot valve	100	部分堵塞加倍 Partial block-up multiplied

注: 例如100mm直管, 底阀折合100倍直径等于100×100=10000mm=10m直径长度, 假定流量为8L/s查上表, 直管每100m损失1.3m, 则10m损失0.13m, 即一个100mm底阀, 流量为8L/s时, 损失扬程0.13m。

Note: For instance, a 100mm diameter pipe, the foot valve has a 100×100=10000mm=10m diameter when which is converted into 100 times that of the pipe's diameter. Suppose the flow is 8L/s. Looked into the above table, the loss of the straight pipe is 1.3m each 100m, then the one for 100mm is 0.13m, that is, for a 100mm foot valve with a flow 8L/s, its head low is 0.13m.

一定管路直径之最大流量限制
Limit of the maximum flow for a pipe with a certain diameter

管径 Pipe diameter (mm)	最大流量 Maximum flow (L/s)	最大流速 Maximum flow rate (m/s)	管径 Pipe diameter (mm)	最大流量 Maximum flow (L/s)	最大流速 Maximum flow rate (m/s)
25	1	2.04	125	130.0	2.44
38	2.5	1.69	150	43.0	2.45
50	4.17	2.12	175	60.0	2.49
65	6.67	2.01	200	83.3	2.69
75	10.0	2.26	250	133.0	2.72
100	18.4	2.33	300	192.0	2.71

注: 超过此限使管路损失显著增加。
Note: The pipeline loss would be made greatly increased once the limit is over.



哈尔滨排水有限责任公司
山东鲁能物资集团公司
锦州石油工程公司
广西净宇环境工程公司
厦门市山海青环保科技有限公司
原平污水处理厂
贵州铝厂
沈阳市自来水水源建设开发有限公司
鞍山鑫龙铝塑有限公司
锦州铁路建筑工程段
无锡力马化工机械有限公司
无锡市焦化厂
重庆东汇实业有限公司
成都海发新世界
成都广通制药成套设备厂
滁州广播电视台
太原昌源洗煤冶炼有限公司
吉林市龙鼎饮品有限公司
镇海众茂物资经营有限责任公司
哈尔滨排水有限责任公司
镇海众茂物资经营有限责任公司
太原昌源洗煤冶炼有限公司
懂家变电所
大庆供水公司
广西玉林玉柴集团康源公司
淮北矿业集团煤矿业有限责任公司
天津华七化工有限公司
郑州锅炉厂
深圳中锋生化工业有限公司
包头铝业(集团)有限责任公司
兰州铁路分局

江都市高鸿环保成套设备工程公司
南京市金晶装饰有限公司
苏州唯葑食品有限公司
新疆众和股份有限公司
河南银鸽实业公司
常州市市妇幼保健院
金坛市金牛环保设备厂
福建纺织化纤集团三明化工公司
上海工程成套公司
昌吉市高新区经济发展有限公司
六盘水市供水总公司
鄂钢集团
陕西万生塑业科技有限公司
广西玉林市玉柴康源水处理公司
广西陆川县宏达钢铁有限公司
北京金港建设有限公司
重庆丽苑大酒店
青岛新机电设备有限公司
天津西青区市政工程管理所
上海工程成套建设有限公司
杭州世达五交化公司
常州市珍虹印染有限公司
金坛市金牛环保设备厂
山东众泰发电有限公司
安阳市水环境规划管理处
上海和川电力科技有限公司
青岛凯利达机电有限公司
江苏水盐工业设备有限公司
南宁市政工程管理处
沈阳吉兴对外经济贸易公司
北京金州工程有限公司

浙江国光生化股份有限公司
山东鲁能物资集团有限公司
无锡通田环境工程有限公司
重庆康达环保股份有限公司
湖州绿通环保工程有限公司
绍兴越兰印染有限公司
青岛光威污水处理有限公司
山西天石电力有限公司
欧亚华都(宜兴)环保有限公司
大连迈克环境科技工程有限公司
郑州纺织机械股份有限公司
郑州纺织机械股份有限公司
苏州市排水管理处
西安长天环保工程有限公司
杭州余杭环科污水处理有限公司
欧亚华都(宜兴)环保有限公司
郑州纺织机械股份有限公司
金坛市金牛环保设备厂
吉林市建龙钢铁有限责任公司
山东诚信工程建设监理有限公司
杭州市市政工程集团有限公司
齐齐哈尔排水公司
绍兴全有机电设备成套有限公司
石家庄天工科技开发有限公司
九江正诚物资工贸有限公司
常州海鸥水处理有限公司
常州东恒印染有限公司
无锡市百纳水处理设备有限公司
四川景天环境治理有限责任公司
新时代集团有限公司
嘉善洪溪污水处理有限公司
吉林省镇赉水利局机械施工队
西安正德水处理有限公司
哈尔滨市沿江排水泵站改造项目
巨野县第二建筑公司
唐山城市排水有限公司
深圳国电科贸物流集团有限公司
海南金海浆纸业有限公司
江苏盛立环保工程有限公司
江苏瑞盛水处理有限公司
明胶有限公司
山西洛安合成油有限公司
中国海诚工程科技股份有限公司
大化集团有限责任公司
银鸽实业投资股份公司
鑫金华宇商贸公司
大连大孤山污水处理有限公司

服务网络

连成在全国各大、中城市设有350多个分支机构，并建立了销售服务网络，拥有一支庞大的销售服务队伍。

服务项目

- 技术培训
- 安装调试
- 维护修理保养
- 设备评估
- 故障处理
- 设备升级改造

服务承诺

- 合同签订后，在安装期间本公司将派人无偿到现场协助安装及调试；
- 如您按说明书正确使用上海连成牌水泵能确保您使用满意，万一发生异常情况，即请拨打服务热线，我们将为您提供优质的售后服务，给予你满意的答复；
- 产品保修期为一年，一年之内如产品出现质量问题，本公司将实行三包：一年以后出现产品质量问题，本公司提供无偿的技术服务，需方单位自购零配件；
- 产品售出后，本公司将终生与客户保持联系，听取使用意见，以便使产品质量更加完善；
- 本公司将定期与定购单位保持联系，定期回访，以确保定购单位使用的设备运行处于良好状态。

Service Network

With a strong team of sales promotion and after-sales-service, Liancheng established more than 350 nation wide branches in various large and middle.

Service Items

- Technical training
- Equipment evaluation
- Installation and adjustment
- Trouble-shooting
- Maintenance and repairing
- The modification & improvement of equipment

Service Promise

After signing the contract, technical persons will be dispatched to the instant site to help install and adjust equipment, which is free of charge.

In case the equipment is manipulated in accordance with instruction of tech manual, Shanghai Liancheng will guarantee the products. If something abnormal occurred, please contact us. Shanghai Liancheng will provide consider. Within the warrant period of 1 year, if products have quality problems, Liancheng will provide charge-free services.

After warrant period, if quality problems occur, will provide the charge-free technical support, the components and parts should be bought by customers.

After the products are purchased, Shanghai Liancheng will keep lifelong contact with the customers, listening comments from customers so as to improve quality in pump performance.

Shanghai Liancheng will keep regular contact with ordering companies so as to have pump running in proper order.

境内售后服务请与我公司当地售后联系或总部：021-59136786

For the domestic post-sale service, please contact the local post-sale service and the headquarter: 021-59136786

境外销售和售后服务请联系：+86 21 59136780

For the abroad sale and post-sale service, please contact: +86 21 59136780

驻外机构：_____

Agency : _____